

ITECHFLOW PRIVATE LIMITED

Type turbine flow meter

Installation instructions



ITECHFLOW PRIVATE LIMITED

Overview	1
iTechflow Basic turbine flow sensor	1
iTechflow type turbine flow transmitter	6
iTechflow type turbine flow sensor	7
iTechflow type turbine flow transmitter	8
Maintenance and common fault	9
Transportation and storage	10
Out of the matters needing attention	10
Ordering information	11

**This product was designed and manufactured according to JB/T
9246—1999 machinery industry standard**

Overview

iTechflow series turbine flow sensor (hereinafter referred to as the sensor), on the basis of the principle of moment balance belongs to speed type flow meter. Sensor has the advantages of simple structure, light, high accuracy, good reproducibility, responsive, use of installation and maintenance is convenient wait for a characteristic, is widely used in petroleum, chemical industry, metallurgy, water supply, paper and other industries, is an ideal instrument to flow measurement and energy saving.

Sensor and display instrument are suitable for measuring the closed pipeline and 1Cr₁₈Ni₉Ti stainless steel, 2 Cr₁₃ and corrode corundum Al₂O₃, cemented carbide, and no fiber, particle impurities such as liquid. If with display instrument with special functions, can also be quantitatively control and excessive alarm, etc. The use of this product explosion-proof type (ExmIIT6), can be used in a environment with explosion danger.

Sensor is suitable for the viscosity under the working temperature is less than $5 \times 10^{-6} \text{ m}^2 / \text{s}$ medium, for viscosity is greater than $5 \times 10^{-6} \text{ m}^2 / \text{s}$ of the liquid, to be used after solid solution to calibrate the sensors.

If users need special kind of sensor, they can negotiate orders, sensor explosion-proof type, In order to illustrate.

iTechflow basic turbine flow sensor

2.1 structure characteristics and working principle

2.1.1 structure characteristics

Sensor is cemented carbide bearing thrust type, not only guarantee the accuracy, wear-resisting performance improvement, and has simple structure, strong and easy disassembling, etc.

2.1.2 working principle

Fluid flowing through the sensor shell, as a result of the impeller blade and flow to a certain point of view, the impact of fluid blade with rotational torque, to overcome the friction torque and fluid resistance, blade rotation speed stability after the moment balance, under certain conditions, the speed is proportional to the velocity of flow, because there are magnetic conductivity blade, it is in the signal detector (consists of permanent magnets and coils) magnetic field, rotating blade cutting lines, periodically changing coil magnetic flux, so that the coil ends induction electrical pulse signal, the signal after amplifier amplification plastic, form a certain amplitude of continuous

rectangular pulse wave, can be spread far to display instrument, show the instantaneous flow or volume of the fluid. Within the scope of a certain flow, pulse frequency f and flows through the sensor of fluid is proportional to the instantaneous flow rate Q , flow equation is: $Q = 3600 \times \frac{f}{k}$

Type:

f — pulse frequency (Hz)

k — the instrument coefficient of sensor 1 / m³, given by the check list. If [1 / L] as the $Q = 3600 \times \frac{f}{k}$

Q — fluid transient flow (working conditions) m³ / h

3600 — conversion factor

Coefficient of each sensor of the instrument in the calibration certificate will be completed by the manufacturer, set into the display instrument of form a complete set of k value, can show the instantaneous flow and cumulative total.

2.2 the basic parameters and technical performance

(1) the basic parameters: table (a)

Table (1)

Product model and sign					instruction	
	iTechflow	□□ □	□	□	□	
Type	iTechflow					Basic, + 12 v power supply, pulse output, high level 8 vor higher Low level 0.8 V or less
	iTechflow					Two wire system 4 ~ 20 ma output current, far eastone - type
	iTechflow					Battery type display at the scene
	iTechdflow					The scene shows two wire / 4 ~ 20 ma current output
Nominal diameter		4				4 mm, ordinary turbine flow range of 0.04 ~ 0.04 m ³ / h Wide-range turbine is 0.04 ~ 0.4 m ³ / h
		6				6 mm, ordinary turbine flow range of 0.1 ~ 0.1 m ³ / h Wide-range turbine is 0.06 ~ 0.6 m ³ / h
		10				10 mm, ordinary turbine flow range of 0.2 ~ 1.2 m ³ / h Wide-range turbine is 0.15 ~ 1.5 m ³ / h
		15				15 mm, ordinary turbine flow range 0.6 ~ 6 m ³ / h Wide-range turbine is 0.4 ~ 8 m ³ / h
		20				20 mm ordinary turbine flow range 0.8 ~ 8 m ³ / h
		25				25 mm, ordinary turbine flow range 1 ~ 10 m ³ / h Wide-range turbine is 0.5 ~ 10 m ³ / h
		40				40 mm, ordinary turbine flow range 2 ~ 20 m ³ / h Wide-range turbine for 1 ~ 20 m ³ / h
		50				50 mm, ordinary turbine flow range 4 ~ 40 m ³ / h Wide-range turbine for 2 ~ 40 m ³ / h
		80				80 mm, ordinary turbine flow range 10 ~ 100 m ³ / h Wide-range turbine is 5 ~ 100 m ³ / h
	100				100 mm, ordinary turbine flow range from 20 to 200 m ³ / h	

				h
				Wide-range turbine is 10 ~ 200 m ³ /h
	150			150 mm, ordinary turbine flow range 30 ~ 300 m ³ /h Wide-range turbine for 15 ~ 300 m ³ /h
	200			200 mm, ordinary turbine flow range of 80 ~ 800 m ³ /h Wide-range turbine is 40 ~ 800 m ³ /h
Explosion proof				No mark for the explosion proof type
	B			explosion proof type
accuracy grade		A		Precision±0.5grade
		B		Precision±1.0grade
Turbine flow type		A		Wide-range turbine
		B		Ordinary turbine

DN4-DN40 - diameter of the sensor for the threaded connection, the maximum working pressure of 6.3 Mpa;

DN50- DN200 caliber sensors for flange connection, the maximum working pressure is 2.5 Mpa.

DN4 - DN10 caliber sensor with a straight pipe, the filter before and after.

DN15 above diameter straight pipe before and after we can form a complete set of sensors.

DN25-DN40 - diameter of the sensor can be made into flange connection, but when ordering.

(2) medium temperature: - 20 ~ + 120 °C.

(3) temperature: - 20 ~ + 55 °C.

(4) the power supply voltage: 12 v + / - 10%, current: 10 ma, or less.

(5) the output voltage amplitude, high level 8 or higher V, low level 0.8 V or less.

(6) transmission distance, the distance of the sensor to display instrument of up to 1000 m.

2.3 installation, use and adjustment

2.3.1 installation

Sensor installs method according to different specifications, using thread or flange connection, the installation method as shown in figure (1), (2), (3), the installation dimensions are shown in table (2).

1. The filter 2. Straight pipe before 3. The impeller

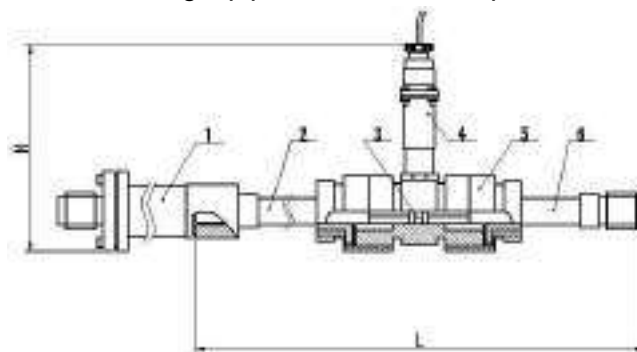

4. The impeller preamplifier 5. Case 6. After the straight pipe

The whole table structure

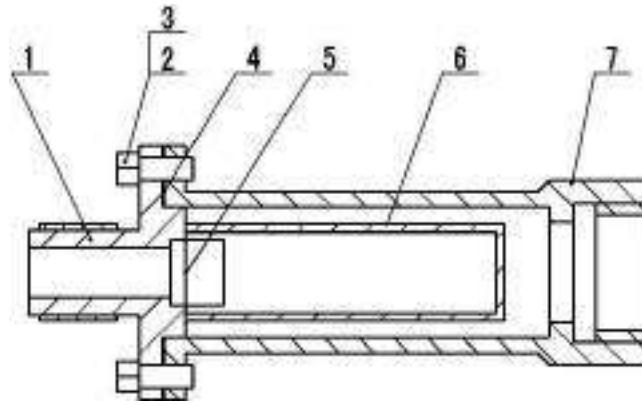

1. The compression ring. 2. The bolt 4 x 14 .3. The washer
 4. gasket sealing gasket 5. Wire 1Cr₁₈Ni₉Ti - 0.8 x 2.5
 6. Screen pack 7. base

The filter structure

Figure (1) LWGY, 4 ~ 10 sensor structure diagram and installation size

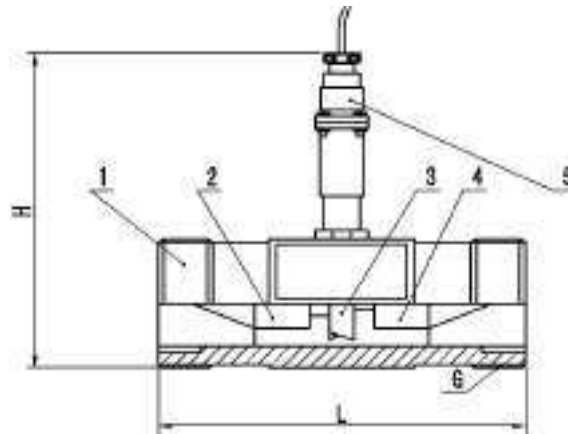

Figure (2) LWGY - 15 ~ 40 sensor structure diagram and installation size

1. Case 2. Guide before a 3. impeller 4. The impeller leads to a 5. After preamplifier

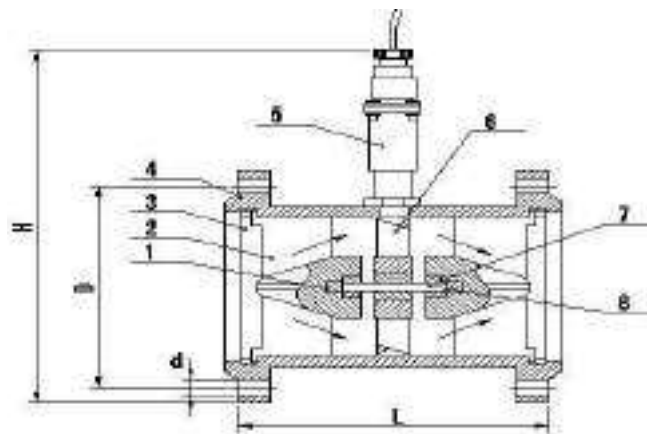

Figure (3) LWGY - 50 ~ 200 sensor structure diagram and installation size

1. The ball bearing 2 ball bearing guide before a 3. The flange
 4 flange shell 5. Preamplifier 6. Impeller 7. bearing 8. Bearing axis

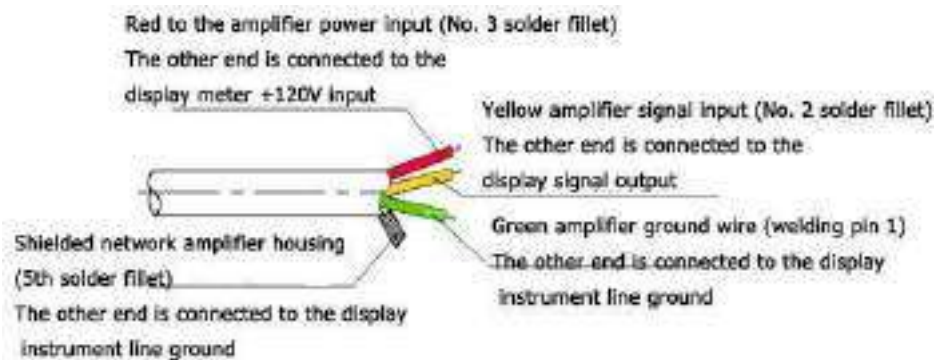

Figure (4) sensor and display instrument wiring diagram

Table (2)

	Nominal diameter (mm)	L(mm)	H(mm)	G	L'(mm)	D(mm)	d(mm)	holes number
i-Tech-4	4	295	145	G1/2	195			
i-Tech -6	6	330	145	G1/2	230			
i-Tech -10	10	450	165	G1/2	350			
i-Tech-15	15	75	173	G1				
i-Tech -25	25	100	180	G5/4				
i-Tech -40	40	140	178	G2				
i-Tech -50	50	150	252			Φ125	Φ18	4
i-Tech -80	80	200	287			Φ160	Φ18	8
i-Tech -100	100	220	322			Φ180	Φ18	8
i-Tech -150	150	300	367			Φ250	Φ25	8
i-Tech -200	200	360	415			Φ295	Φ23	12

Note:

Sensors can be horizontal and vertical installed, vertical installation direction of flow must be upward. Liquid should be full of pipes, can not have bubbles. the flow liquid direction should be the direction of the arrow and indicating flow sensor shell When installing. Sensors upstream side should have a straight pipe at least 20 times the length of the nominal diameter, the downstream end shall have a straight pipe section not less than five times the length of the nominal diameter, and its inner surface should be smooth and clean, no dent, fouling and defects such as peeling. The pipe axis of sensor shall be aligned with the adjacent pipe axis, and the gasket for connecting seal may not be deeply into the pipe cavity.

Sensors should be far away from the external electric field, magnetic field, the effective shielding measures should be taken when necessary to avoid the outside interference.

In order not to affect the normal liquid delivery when maintenance , you should install bypass pipe in the installation of sensors.

Please dispose the waterproof processing of amplifier and plug when installing Sensor openly.

Sensors and the connection of display instrument as shown in figure 4.

When the fluid contains impurities you should be equipped with filter whose mesh accord to the flow of impurities, as a general rule, be 20 ~ 60 mesh. When mixed with the free gas in the fluid you should add the venting device. The whole pipeline system should be well sealed.

Users should fully understand the corrosion situation of measured medium fighting sensor from corrosion.

2.3.2 use and adjust

When using measured liquid should maintain clean, do not contain impurities such as fiber and particles.

At the beginning of the use sensors should be slowly filled with liquid , and then open the outlet valve. it is strictly prohibited to sensors by the impact of high speed fluid when empty in sensor.

The maintenance period of sensor is commonly half a year. When cleaning please note that you are the measuring chamber of damaged parts, especially in the impeller. Please watch the orientation and the position of the impeller when assembling.

Inside liquid of Sensor should be cleaned when you do not need it, and protective sleeves should be covered on both ends of the sensor preventing dirt to enter, and then keep in a dry place.

The filter should be cleaned regularly. when you do not need it you should clean the internal liquid the same as sensors, dustproof set, keeping in a dry place.

Sensor cable can be raised or direct buried (when buried iron pipe should be set).

Before installed sensor should be connected with display instrument or oscilloscope and power supply, blow with mouth or hand dial the impeller to make it rapidly rotate observing display. sensor was installed when have shown. If no display, you should check the relevant parts, troubleshooting.

i-Tech type turbine flow transmitter

Figure (5)



Based on the i-Tech basic turbine flow sensor, i-Tech type turbine flow transmitter increased the function of 24 VDC power supply, two wire system 4-20 ma current transmitting function, especially suitable for computer, such as display, industrial control, DCS control system.

The diameter of the flow measurement range in this transmitter, sensor structure size, installation method, maintenance and so on are in the second part, please read this manual "LWGY prototype turbine flow sensor".

Flow calculation formula:
$$Q = \frac{I - 4}{16} Q_F$$

Type:	Q	——	actual flow (m ³ /h)
	Q _F	——	limit on the flow measurement, m ³ /h, see table (a)
	I	——	output current (mA)

Transmitter power supply voltage: 24V, (12V–30V)

Power supply voltage and load resistance relations:
$$R_{LMAX} = \frac{U - 12}{0.02} - 50$$

Type:	R _{LMAX}	——	maximum load resistance (Ω)
	U	——	the power supply voltage (V)

Transmitter connection:	red line	——	24V+
	Black (green) line	——	0V

i-Tech Flange type turbine flow sensor



on the basis of i-Tech prototype turbine flow sensor type scene shows

the turbine sensor uses battery power and strengthen the function of scene shows. The flow meter is a new flow measurement instrument integrating advanced technology of ultra-low power consumption single chip microcomputer development integration of sensor with display product. Compared With measuring system of traditional turbine flow sensor match with secondary instrument, it has the advantages of small volume, light weight, the display reading intuitive, clear, high reliability no external power supply, lightning resistance, complete low cost sets advantages. It can be widely used for liquid flow measurement in petroleum, chemical industry, light industry, food industry and so on. This product performance which is superior reached the international advanced level of similar products.

The flow range of the meter of each diameter, the flow meter sensor structure size, installation method, maintenance and so on are in the second part, please read this manual LWGY basic turbine flow sensor.

4.1 the main technical indicators

(1) display mode:

double row liquid-crystal display (LCD), as follows:





L XXX. X four instantaneous flow (m³/h)

XX. XXXXXX eight cumulative flow (m³)

- (2) the system low power consumption: section 3.3 V10AH lithium batteries can be used more than 5 years in a row.
- (3) the cumulative flow: automatically expand the display precision, the cumulative flow values can be reset.
- (4) the meter factor: the scene can be put into.
- (5) power-fail protection: instrument coefficient and total flow values to maintain power down ten years

4.2 The number setting method of three coefficient double row liquid-crystal display instrument: (only authorized engineer operation)

Open the front cover, buttons  and F keys at the same time, the instrument enter into the state of load, now ranked the first digital display 1 said at this time can be set up the instrument coefficient of the first point.. After the four sensor output can be set up corresponding points of the pulse frequency, the lower eight bits can be set the point of the instrument.

First, highest twinkle, buttons , the bit to add 1 to the required value, press the shift key , blinking moves to the right, with a button  to choose the bit numerical... When flashing displacement to the last, button , to put this parameter re-implantation. Instrument coefficient of format for XXXXXX. XX.

Check and correct after pressing the F key, can enter the next point meter coefficient setting, setting method, the above format.

Setting up the three coefficients continues to press the F key, the instrument enter into the state of work, upper row shows four in flow, cumulative flow discharge display eight.

In working status, press the F key and key , the accumulative total amount can be reset.

Note: The nonlinear correction using three instrument coefficient of flow sensor requires the user to know what are the coefficients corresponding to different flow meter sensor point, namely F₁- K₁, F₂ - K₂, F₃ -- K₃.

i-Tech type turbine flow transmitter

5.1 Based on the i-Tech type turbine flow sensor i-Tech type turbine flow transmitter increases the 24 VDC power supply, two wire system 4-20 ma current transmitting function, especially suitable for use with computer control system such as display, industrial, DCS. It also has the function display and remote transmission.





5.2 The operating methods of setting the instrument coefficient refers to the explanation of "four, i-Tech type turbine flow sensor" setting part, the difference are as follows:

5.2.1 The operation method of three coefficient double row liquid-crystal display instrument: (only authorized engineer operations) .

Open the front cover, press the F key and  key at the same time, the instrument enter into the state of load.

Now ranked the first number is 1, the remaining four location are frequency values which go through this sensor, coefficient of discharge can be put into this instrument and meter coefficient

format for XXXXXX. XX.

First, highest twinkle, buttons  , the bit to add 1 to the required value, press the shift key  , blinking moves to the right, With a key  Pick the numerical... , When flashing displacement to the last, Press the key,  To put this parameter again;

Check and correct after pressing the F key, can enter the next set of factor set, ranked first show 2, above the rest.

Check and correct after pressing the F key, can enter the next set of factor set, ranked the first display 3, above the rest.

If continue to press the F key, instrument Sets the fourth parameter - full of traffic. Now fold 20mA the corresponding flow full scale value into the lower row, such as 4 mm corresponds to 250L/h, at this point can be put into 250; If post 50, 50L/h corresponds to 20 ma automatically.

Set the parameters, check and correct, at the same time press the F key then go to work station, the upper row display the five instantaneous flow, the lower row display the eight total flow.

In working status, press the F key and  key at the same time, the accumulative total amount can be reset

Instrument have been adjusted again before they leave the factory parameter, generally do not need to be adjustable.

If under normal use conditions, the output of remote current is far short of the theoretical value, please adjust as follows , adjust the adjustable resistance of the circuit boards: open the instrument front-shell, take out the circuit board, in the next layer of circuit boards have two adjustable resistance, adjusting the V3 can adjust 4 ma, adjusting the V4 can adjust 20 ma, pay attention to don't adjust the amplitude adjustment too large. After adjustment is installed.

5.3 transmitter connection:

The red line - 24 v +

Black (green) line - 0 v

Maintenance and common fault

The general faults of sensors may be produced and eliminating methods are shown in table (3), the maintenance period shall not exceed six months.

Table (3)

serial number	fault phenomenon	cause	The solution
1	Display of traffic signals and inspection are no display	1. The power supply is not connected or given voltage is not correct. 2. Display is faulty.	1. Connect the power supply, according to the requirements for a given voltage. 2. Maintenance display instrument..
2	Display instrument of "check" signal but no display of the traffic signal.	1. The sensor and display the indirect line is wrong, or open circuit, short circuit, such as poor contact failure.	1. The comparison chart 4, check the correct wiring and connection quality. 2. Repair or replace the amplifier.

serial number	fault phenomenon	cause	The solution
		2. The amplifier has a fault or damage. 3. The converter (coil) open circuit or short circuit. 4. The impeller jammed. Pipeline without fluid flow or jam.	3. Repair or replace the coil. 4. Sensors and pipe cleaning. Open the valve or pump, pipeline cleaning.
3	Display instrument working instability; Measurement is not correct.	1. The actual flow is beyond the scope of instrument measurement or working condition is not stable. 2. The meter coefficient K set wrong. 3. Hang impurities such as fiber sensor inside. 4. A bubble in the liquid. 5. By the sensor has the strong electromagnetic interference. 6. The sensor bearing and shaft serious wear and tear. 7. The sensor or other grounding wire and cable shielding layer circuit ground wire broken or poor contact. 8. Display instrument malfunction	1. Make the measured flow and sensor measurement range, and steady flow. 2. Make coefficient K is set correctly. 3. Cleaning the sensor. 4. Venting measures to eliminate air bubbles. 5. Far away from disturbance sources as far as possible or shielding measures. 6. Replace the "guide" or "impeller shaft". 7. Control chart, four line will connect well. 8. Maintenance display instrument.

Under the condition of complying with the specification of safekeeping and use, within one year from the factory delivery, sensors for producing bad that can't work normally, factory for free repair.

Transportation and storage

7.1 sensor should be in strong wooden case (small diameter instrument available in cartons), not allowed running freely in the cabinet, handle with care when handling, do not allow the rough handling.

7.2 location shall meet the following conditions:

- a. Rain moisture proof.
- b. Do not affected by mechanical vibration or impact.
- c. Temperature range - 20 °C ~ + 55 °C.
- d. Relative humidity is not greater than 80%.
- e. No corrosive gas in the environment.

Out of the matters needing attention

8.1 when unpacking the case, according to the packing list to check the documents and the attachment is complete.

A packing files include: operation instruction

Verification certificate

The packing list.

8.2 observe the phenomenon such as the sensor for due to transportation damage, in order to properly handle.

8.3 hope users keep "calibration certificate" do not lose, otherwise unable to set the meter factor!

Ordering information

9.1 When user order turbine flow sensor you should pay attention to the appropriate specifications based on fluid nominal diameter, working pressure, working temperature, the flow range, the type of fluid and environmental conditions. When have explosion-proof requirements you must choose explosion-proof type sensor, and strict attention to explosive-proof grade.

9.2 When user need my company display instrument to form a complete set you should refer to the corresponding specifications, choose suitable model, or design your mode selection provided by our company technical personnel based on your information. Indicate the specifications and cable length when you need to use cable to transmit signal.

ITECHFLOW PRIVATE LIMITED

Regd. Office -

30, Jhotwara industrial Area, Jaipur ,Rajasthan-302012

Contact No: +91-08851783652 / +91-9660249450

[Email-itechflow1@gmail.com](mailto:itechflow1@gmail.com) | info@itechflow.com

Website:- www.itechflow.com